

image



iPro 60E/80E/100E/150E LED Outdoor Gobo Projector



Instruction/User Manual and Specifications

Package Contents

Projector, optical lens and cable with standard 110 Volt plug.

Description

iPro “E” LED projectors are rated IP-65 for outdoor use. To project an image, a high resolution glass or metal gobo is required. To order a gobo, e-mail the artwork of the desired image to Info@UseLight.com. Line-art or vector files are acceptable, as are pixel files (e.g. .JPEG, .PNG, .TIFF, .PDF, etc.) 300 dpi or better.

Safety Information

- For indoor or outdoor use.
- Prevent direct eye exposure to the light source as it may lead to injury or blindness.
- The projector may generate heat. Please use caution when handling or touching the unit during and after operation.
- Only use power sources that comply with local electrical and building codes and have proper grounding.

Gobo Specifications

- Outer diameter (OD) - 37.5 mm
- Inner or image diameter (ID) - 25 mm
- Gobo thickness: Up to 3 mm

Projector Specifications

Model:	iPro-60E	iPro-80E	iPro-100E	iPro-150E
Voltage:	110 to 277 V*	110 to 277 V*	110 to 277 V*	110 to 277 V*
Lamp (LED):	60 W	80 W	100 W	150 W
Rated Frequency:	50/60 Hz	50/60 Hz	50/60 Hz	50/60 Hz
LED Lamp Life:	30 - 40,000 Hrs	30 - 40,000 Hrs	30 - 40,000 Hrs	30 - 40,000 Hrs
Color Temp. (K):	6,000 - 6,500 K	6,000 - 6,500 K	6,000 - 6,500 K	6,000 - 6,500 K
Luminous flux:	5,400 lm	7,200 lm	9,000 lm	13,500 lm
Weight:	8 lbs.	8.5 lbs.	8.5 lbs.	8.5 lbs.

* US only - 240 V outside of US

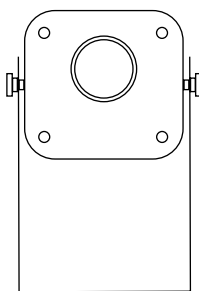

Front View

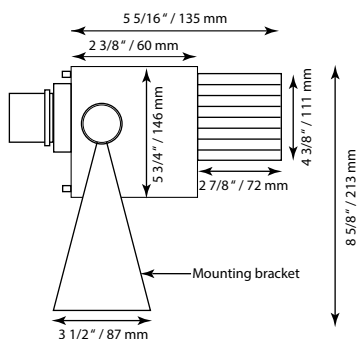

Side View

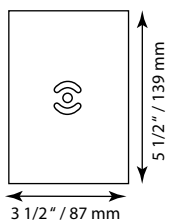

Bottom View

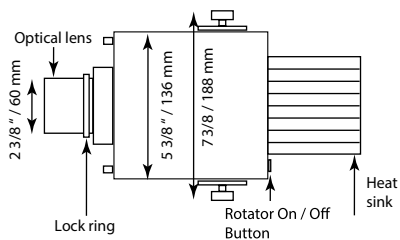

Top View

Warranty

This projector comes with a 1-year warranty that begins on the date of purchase and includes labor and parts.

Gobo Installation and Exchange



Step 1

Unlock the lens lock ring by unscrewing it counter clockwise. Then turn the optical lens counter clockwise until it comes off.



Step 2

Remove the metal pressure clip by squeezing together the two bent ends.

WARNING: PLEASE USE CAUTION WHEN REMOVING OR INSTALLING THE PRESSURE CLIP, AS IT MAY SPRING OR JUMP OUT UNEXPECTEDLY.



Step 3

Place the gobo with image facing down (reversed) in the gobo slot.



Step 4

Place the metal pressure clip on top of the gobo and make sure it is pressing against the gobo evenly.



Adjusting the Image Focus

Once the gobo is successfully installed and the front plate cover is reattached, rotate the lens clockwise or counter-clockwise until the image is in focus.



Once the image is in focus, turn the lock ring clockwise until the rubber gasket is slightly compressed.

Turning Rotating Effect ON/OFF

Press the button located on the back of the projector to turn the rotator ON or OFF.



image

